

# **HIK**VISION

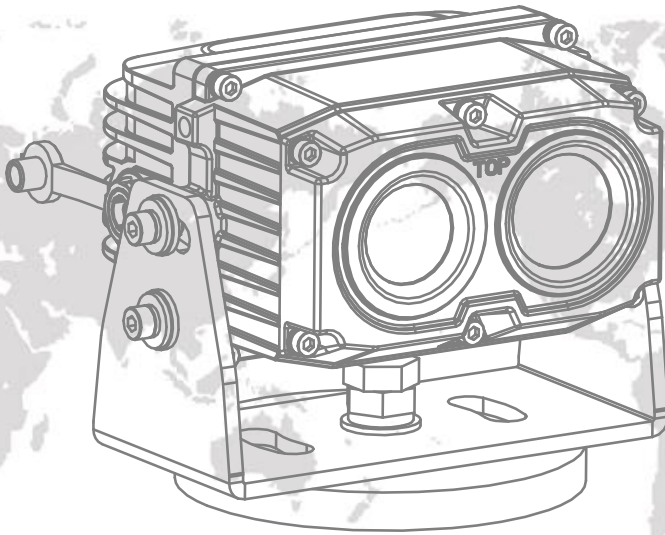

## Thermal Driving Assistance System

### User Manual

## User Manual

COPYRIGHT ©2018 Hangzhou Hikvision Digital Technology Co., Ltd.

### **ALL RIGHTS RESERVED.**

Any and all information, including, among others, wordings, pictures, graphs are the properties of Hangzhou Hikvision Digital Technology Co., Ltd. or its subsidiaries (hereinafter referred to be "Hikvision"). This user manual (hereinafter referred to be "the Manual") cannot be reproduced, changed, translated, or distributed, partially or wholly, by any means, without the prior written permission of Hikvision. Unless otherwise stipulated, Hikvision does not make any warranties, guarantees or representations, express or implied, regarding to the Manual.

### **About this Manual**

This Manual is applicable to **Thermal Driving Assistance System**.

The Manual includes instructions for using and managing the product. Pictures, charts, images and all other information hereinafter are for description and explanation only. The information contained in the Manual is subject to change, without notice, due to firmware updates or other reasons. Please find the latest version in the company website (<http://overseas.hikvision.com/en/>).

Please use this user manual under the guidance of professionals.

### **Trademarks Acknowledgement**

**HIKVISION** and other Hikvision's trademarks and logos are the properties of Hikvision in various jurisdictions. Other trademarks and logos mentioned below are the properties of their respective owners.

### **Legal Disclaimer**

TO THE MAXIMUM EXTENT PERMITTED BY APPLICABLE LAW, THE PRODUCT DESCRIBED, WITH ITS HARDWARE, SOFTWARE AND FIRMWARE, IS PROVIDED "AS IS", WITH ALL FAULTS AND ERRORS, AND HIKVISION MAKES NO WARRANTIES, EXPRESS OR IMPLIED, INCLUDING WITHOUT LIMITATION, MERCHANTABILITY, SATISFACTORY QUALITY, FITNESS FOR A PARTICULAR PURPOSE, AND NON-INFRINGEMENT OF THIRD PARTY. IN NO EVENT WILL HIKVISION, ITS DIRECTORS, OFFICERS, EMPLOYEES, OR AGENTS BE LIABLE TO YOU FOR ANY SPECIAL, CONSEQUENTIAL, INCIDENTAL, OR INDIRECT DAMAGES, INCLUDING, AMONG OTHERS, DAMAGES FOR LOSS OF BUSINESS PROFITS, BUSINESS INTERRUPTION, OR LOSS OF DATA OR DOCUMENTATION, IN CONNECTION WITH THE USE OF THIS PRODUCT, EVEN IF HIKVISION HAS BEEN ADVISED OF THE POSSIBILITY OF SUCH DAMAGES.

REGARDING TO THE PRODUCT WITH INTERNET ACCESS, THE USE OF PRODUCT SHALL BE WHOLLY AT YOUR OWN RISKS. HIKVISION SHALL NOT TAKE ANY RESPONSIBILITIES FOR ABNORMAL OPERATION, PRIVACY LEAKAGE OR OTHER DAMAGES RESULTING FROM CYBER ATTACK, HACKER ATTACK, VIRUS INSPECTION, OR OTHER INTERNET SECURITY RISKS; HOWEVER, HIKVISION WILL PROVIDE TIMELY TECHNICAL SUPPORT IF REQUIRED.

SURVEILLANCE LAWS VARY BY JURISDICTION. PLEASE CHECK ALL RELEVANT LAWS IN YOUR JURISDICTION BEFORE USING THIS PRODUCT IN ORDER TO ENSURE THAT YOUR USE CONFORMS THE APPLICABLE LAW. HIKVISION SHALL NOT BE LIABLE IN THE EVENT THAT THIS PRODUCT IS USED WITH ILLEGITIMATE PURPOSES.

IN THE EVENT OF ANY CONFLICTS BETWEEN THIS MANUAL AND THE APPLICABLE LAW, THE LATER PREVAILS.

## Regulatory Information

### FCC Information

FCC compliance: This equipment has been tested and found to comply with the limits for a digital device, pursuant to part 15 of the FCC Rules. These limits are designed to provide reasonable protection against harmful interference when the equipment is operated in a commercial environment. This equipment generates, uses, and can radiate radio frequency energy and, if not installed and used in accordance with the instruction manual, may cause harmful interference to radio communications. Operation of this equipment in a residential area is likely to cause harmful interference in which case the user will be required to correct the interference at his own expense.

### FCC Conditions

This device complies with part 15 of the FCC Rules. Operation is subject to the following two conditions:

1. This device may not cause harmful interference.
2. This device must accept any interference received, including interference that may cause undesired operation.

### EU Conformity Statement



This product and, if applicable, the supplied accessories are marked with "CE" and comply therefore with the applicable harmonized European standards listed under the Radio Equipment Directive 2014/53/EU, the EMC Directive 2014/30/EU, the RoHS Directive 2011/65/EU.



2012/19/EU (WEEE directive): Products marked with this symbol cannot be disposed of as unsorted municipal waste in the European Union. For proper recycling, return this product to your local supplier upon the purchase of equivalent new equipment, or dispose of it at designated collection points. For more information see: [www.recyclethis.info](http://www.recyclethis.info).



2006/66/EC (battery directive): This product contains a battery that cannot be disposed of as unsorted municipal waste in the European Union. See the product documentation for specific battery information. The battery is marked with this symbol, which may include lettering to indicate cadmium (Cd), lead (Pb), or mercury (Hg). For proper recycling, return the battery to your supplier or to a designated collection point. For more information see: [www.recyclethis.info](http://www.recyclethis.info).



### Industry Canada ICES-003 Compliance

This device meets the CAN ICES-3 (A)/NMB-3(A) standards requirements.

## Warnings and Cautions

- All the electronic operation should be strictly compliance with the electrical safety regulations, fire prevention regulations and other related regulations in your local region.
- Please use the power adapter, which is provided by normal company. The power consumption cannot be less than the required value.
- Do not connect several devices to one power adapter as adapter overload may cause over-heat or fire hazard.
- Do not drop the device or subject it to physical shock, and do not expose it to high electromagnetism radiation. Avoid the equipment installation on vibrations surface or places subject to shock (ignorance can cause equipment damage).
- Do not place the device in extremely hot (refer to the specification of the device for the detailed operating temperature), cold, dusty or damp locations, and do not expose it to high electromagnetic radiation.
- The device cover for indoor use shall be kept from rain and moisture.
- Exposing the equipment to direct sun light, low ventilation or heat source such as heater or radiator is forbidden (ignorance can cause fire danger).
- Do not aim the device at the sun or extra bright places. A blooming or smear may occur otherwise (which is not a malfunction however), and affecting the endurance of sensor at the same time.

# Table of Contents

<b>About This Manual</b> .....	<b>1</b>
Overview of Contents .....	1
<b>1 Overview</b> .....	<b>2</b>
1.1 Description .....	2
1.2 Functions .....	2
1.3 Appearance .....	2
1.3.1 Dimensions .....	3
1.3.2 Interface Description .....	5
<b>2 Installation</b> .....	<b>6</b>
2.1 Preparation .....	6
2.2 Camera Installation.....	6
2.2.1 Magnetic Installation.....	6
2.2.2 Base Installation.....	8
2.2.3 Pendant Installation.....	9
2.3 Display Installation.....	10
2.3.1 Installation with Velcro.....	11
2.3.2 Installation with Screws .....	12
2.4 Cable Connection .....	13
<b>3 Basic Operations</b> .....	<b>15</b>
3.1 Power On/Off .....	15
3.1.1 Power On .....	15
3.1.2 Power Off.....	15
3.2 Button Description .....	15
3.3 Menu Description .....	16
<b>4 System Setup</b> .....	<b>19</b>
4.1 System Correction .....	19
4.2 De-Ice Heater Configuration .....	20
4.3 Palettes Settings .....	21
4.4 Brightness and Contrast Settings .....	21
<b>5 Smart Detection</b> .....	<b>22</b>
<b>6 Appendix</b> .....	<b>23</b>
6.1 Content List.....	23
6.2 Common Material Emissivity Reference .....	24

# About This Manual

This document introduces the **Thermal Driving Assistance System**.

It covers what is night vision driving assistance system, device powering on/off, installation, how to set thermal view/visible light view. Besides, it shows concrete functions and descriptions of the system.

## Overview of Contents

This document contains the following chapters, and appendixes:

**Chapter 1 Overview** introduces the system, including the main description, major functions, appearance, and interface/menu description.

**Chapter 2 Installation** shows you how to install the system onto your vehicle, and how to connect the cables.

**Chapter 3 Basic Operations** describes powering on/off the system, button and menu description.

**Chapter 4 System Setup** shows you the way to configure heater, palettes, and brightness and contrast configuration of the image and the screen.

**Chapter 5 Smart Detection** describes the smart detection and alarm.

**Chapter 6 Appendix** lists the content list, and the emissivity value of common materials for reference.

# 1 Overview

## 1.1 Description

The **Thermal Driving Assistance System** (*driver's system* for short) is an optical system for vehicle driving during the night, even without light. The driver can see the passengers, animals, or other objects in the view, and react to any potential risks.

It helps the driver to see the road clear with low illumination, in fogs, smokes, and even in total darkness. Therefore it ensures the driving security.

## 1.2 Functions

- High performance chip
- DDE (Digital Detail Enhancement) technique
- LED display
- User-friendly design
- IP67

## 1.3 Appearance

The **Thermal Driving Assistance System** has a camera, a display, and other accessories. There are two camera types: thermal lens camera, and thermal & optical dual-lens camera.

### 1.3.1 Dimensions

Refer to the figure below for thermal lens camera dimensions.

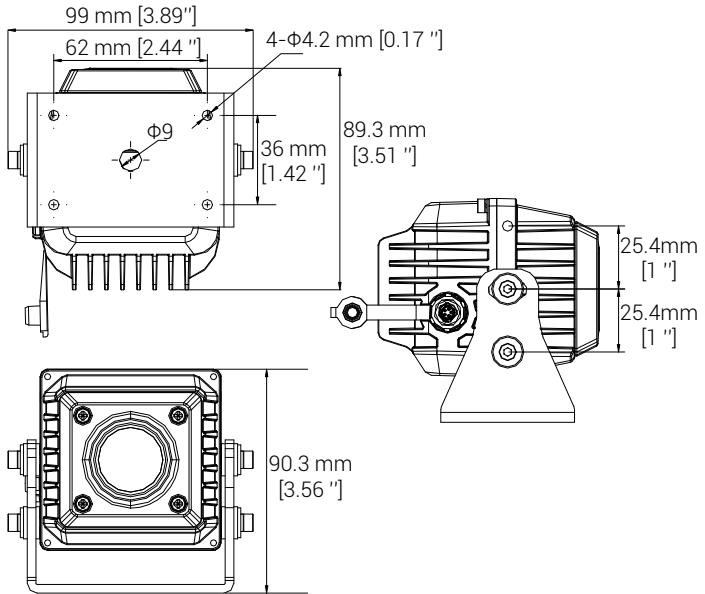

Refer to the figure below for thermal & optical dual-lens camera dimensions.



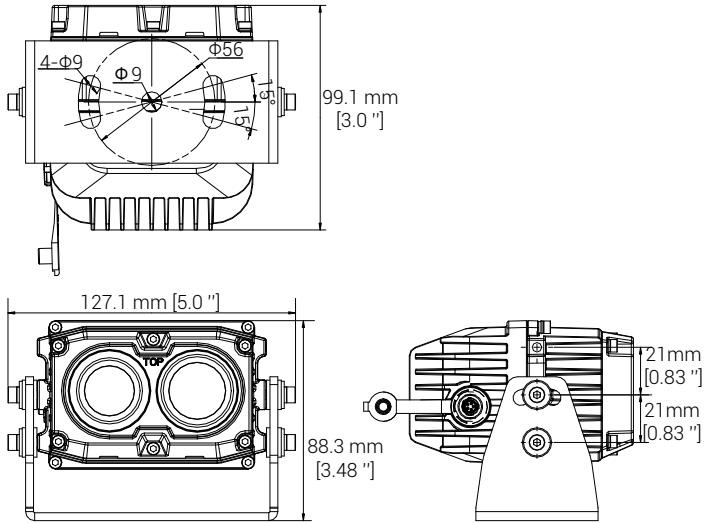

Refer to the figure below for the display dimensions.

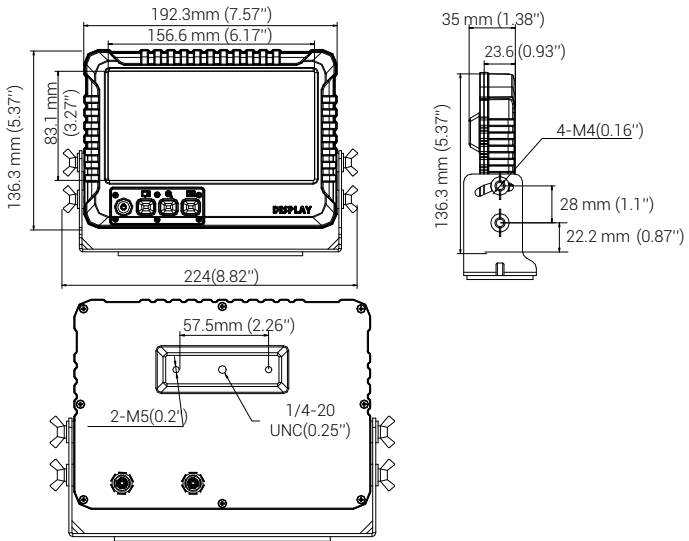

## 1.3.2 Interface Description

Refer to the figure and table for the description of the ports and interfaces of camera and display.

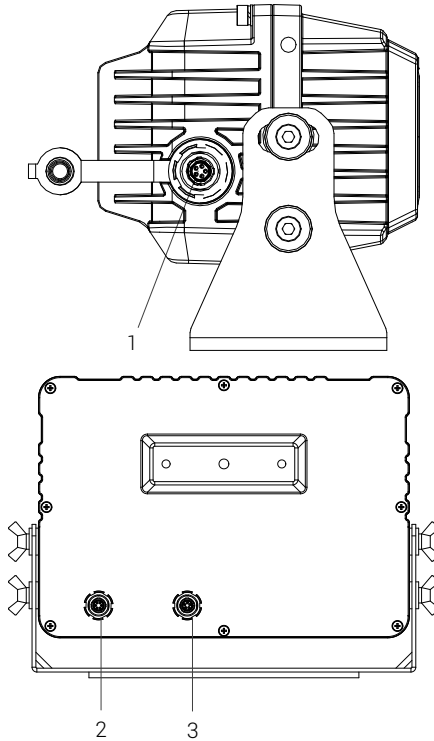

1	<b>Data Output Interface</b>	Connect to Data input interface. Export the data from the camera and provide power for the camera.
2	<b>Power Interface</b>	Provide power resource for the system.
3	<b>Data Input Interface</b>	Connect to Data output interface.

## 2 Installation

The installation of thermal lens camera, and the installation of thermal & optical dual-lens camera are alike, here we take the installation of dual-lens camera as an example.

### 2.1 Preparation

- Make sure the device in the package is in good condition and all the assembly parts are included.
- Make sure that the wall is strong enough to withstand four times the weight of the camera and the bracket.

### 2.2 Camera Installation

There are three types of installation: magnetic installation, pendent installation, and base installation.

#### 2.2.1 Magnetic Installation

**Notes:**

- The system is secured to the vehicle roof with the ferromagnetic plate. The glue of metallic plate (purchased separately) can NOT be used repeatedly, make sure you place it in the right place at once.
- If the vehicle roof is ferromagnetic, skip the first two steps.

**Steps:**

1. Clear the vehicle roof.
2. Slightly bend the magnetic plate (purchased separately) as the curvature of the vehicle roof and make sure that the plate fits the vehicle properly.

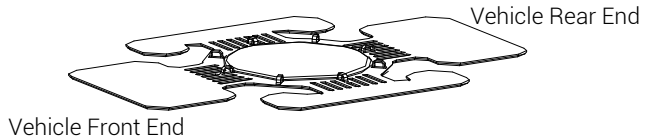

3. Fix the camera.
  - a) For non-ferromagnetic vehicle, secure the camera to the middle of the magnetic plate, and make sure the lens faces the front.

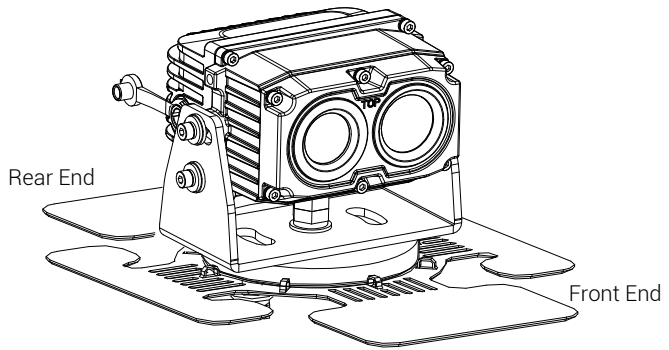

- b) For ferromagnetic vehicle, secure the camera to the vehicle roof.
4. Loosen the four screws and adjust the camera's tilt angle (range:  $-20^{\circ}$  to  $+20^{\circ}$ ), and then tighten the screws.

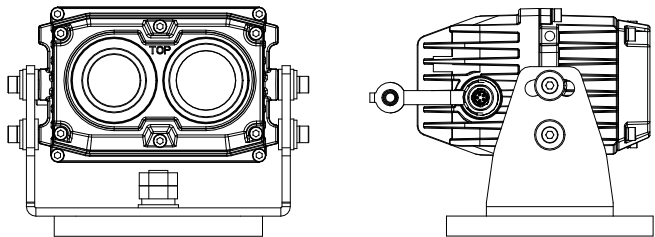

## 2.2.2 Base Installation

### Steps:

1. Loosen the screw on the bottom of the camera, and take apart the nuts and washer.

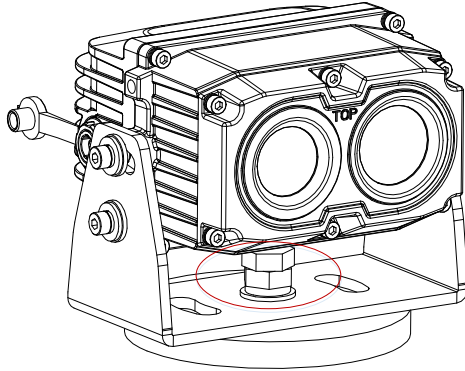

2. Take the camera body away from the bracket.

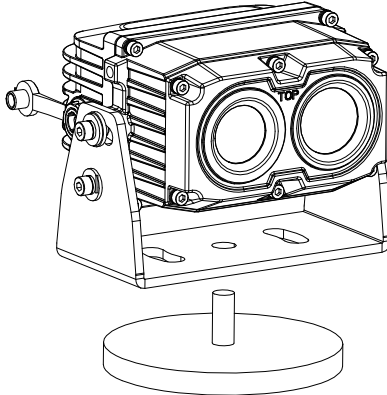

### Note:

Keep the washer, screws, and other accessories.

3. Loosen four screws to take apart the camera body and the bracket.
4. Fix the bracket onto the horizontal surface with two M6\*30 screws.

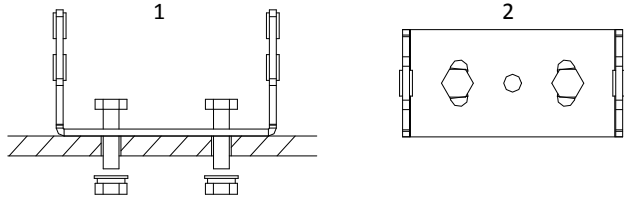

5. Install the camera onto the bracket with four screws, and do not fix the screws.

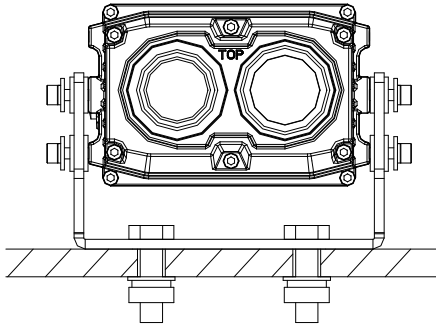

6. Adjust the tilting angle of the camera and then tighten the screws.

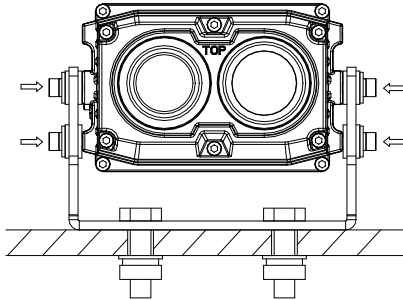

## 2.2.3 Pendant Installation

### Steps:

1. Follow the step 1 to step 3 of section 2.2.2.
2. Fix the bracket onto the ceiling with two M6\*30 screws.

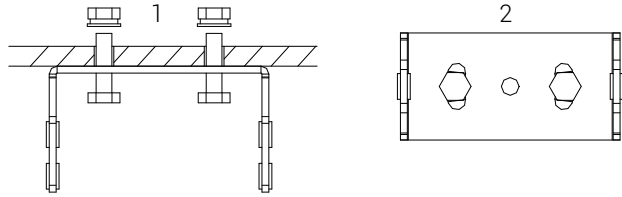

3. Install the camera onto the bracket with four screws, and do not fix the screws.

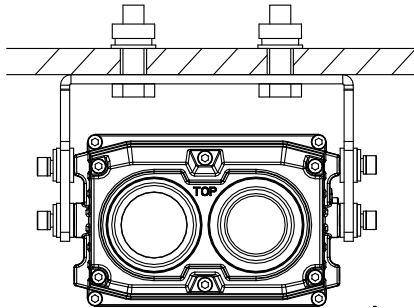

4. Adjust the tilting angle of the camera and then tighten the screws.

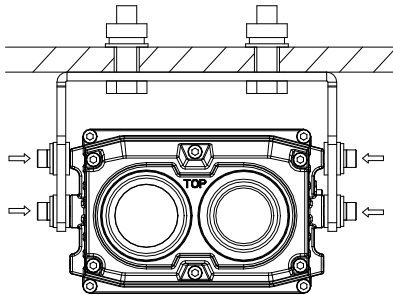

## 2.3 Display Installation

Installation with Velcro and installation with screws are selectable. Velcro is recommended.

## 2.3.1 Installation with Velcro

### **Before you start:**

The glue of the Velcro can NOT be used repeatedly, make sure you place it in the right place at once.

### **Steps:**

1. Install the suction cup mount (purchased separately) to the display by screwing the mount to the end.

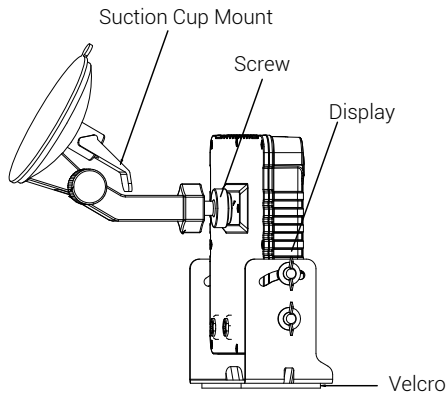

2. Place the display on the vehicle's instrumental panel and attach the suction cap to the vehicle's front window.
3. Adjust the position with the universal joint and tilt adjust screw.



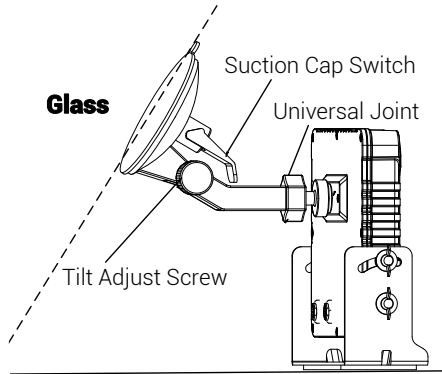

### Instrumental Panel

4. Clear the display with the proper cloth.
5. Tear up the Velcro film and secure the display on the vehicle with the screws.

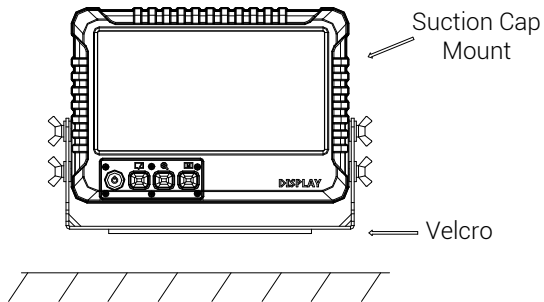

## 2.3.2 Installation with Screws

Secure the display with four A4\*10 self-tapping screws.

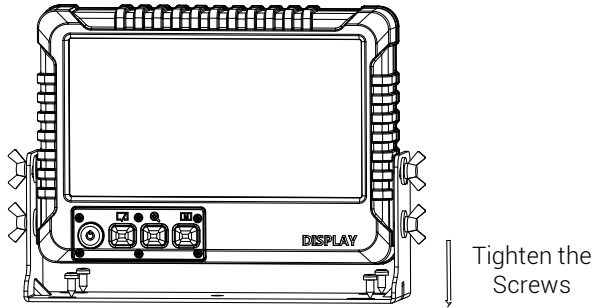

## 2.4 Cable Connection

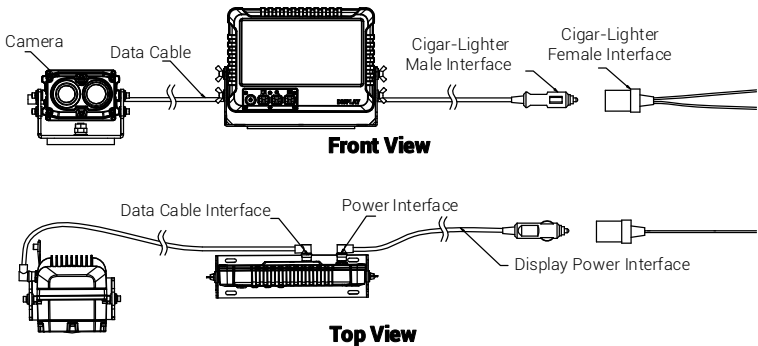

### *Purpose:*

Connect the cables to power on the driver's system with the vehicle.

### *Step:*

1. Connect the camera with display.
  - Connect the green end of cable to the camera, and the red end of cable to the display.
  - Make sure the red spots of the connectors are aligned, and then connect the cables.

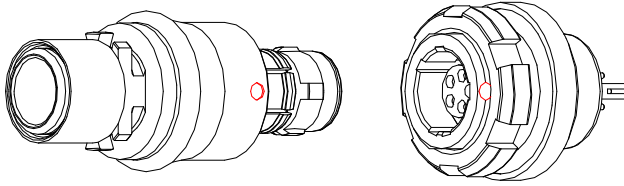

2. Connect the display with the cigar light to power on the display.

Or,

Connect the cigar lighter female interface with the male interface, and then connect the cable to the vehicle terminal box.



**Attention:**

To power up the driver's system with the terminal box, make sure you connect the red line to the positive terminal, and the black line to the GND terminal.

3. Use the cable clamps to secure the cables, and paste the clamps on the vehicle surface.

**Notes:**

- Paste the clamps in correct place in once.
- The large clamps are used for securing the aviation plug, and the small clamps are used for securing the cigar lighter and cables.

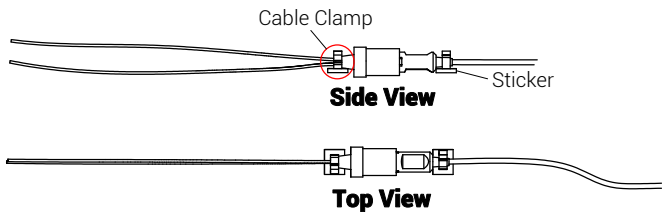

## 3 Basic Operations

### 3.1 Power On/Off

#### 3.1.1 Power On

Make sure the system is powered, and press the **Power** button to turn on the system.

When the live view of camera shows, and the Activating view disappears, the system is turned on successfully.

#### 3.1.2 Power Off



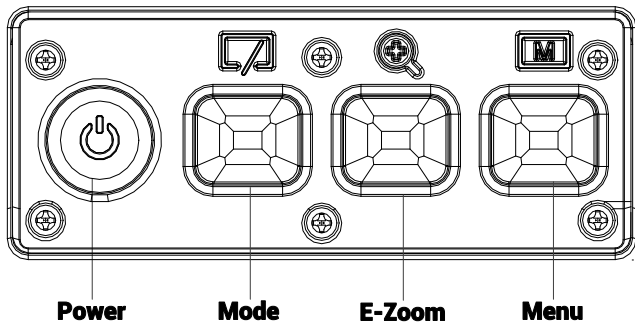

When the system is powered on, hold the Power button for three seconds to power off the device.

### 3.2 Button Description



On the front panel of the display there are four buttons: Power, Mode, E-Zoom, and Menu. The functions of these buttons are shown below:



**In Non-Menu Mode:**

	<b>Power</b>	Press/Hold: Turn on the display.
	<b>Mode</b>	Press: Switch among three image modes. Hold: Enable manual shutter.
	<b>E-Zoom</b>	Press: Display digital zoom. Hold: Enable heater.
	<b>Menu</b>	Press: Switch among the image brightness, image contrast, display brightness, and display contrast interfaces. Hold: Enter/exit the menu.

**Notes:**

- When the system is powered off abnormally, press the **Power** button to restart the system.
- When there is mist or ice on the lens, enable the heater. The heater icon  shows, and the heater stops when the lens is warm enough.
- When you press the menu button to switch among Image Brightness, Image Contrast, Display Brightness, and Display Contrast:
  - Press the **Mode** button to decrease the value.
  - Press the **E-Zoom** button to increase the value.

**In Menu Mode:**

	<b>Mode</b>	Move cursor upward. Decrease the value.
	<b>E-Zoom</b>	Move cursor downward. Increase the value.
	<b>Menu</b>	Confirm

### 3.3 Menu Description

Hold the **Menu** button to enter system menu.

→ Mounting Height	120cm
Elevation Angle	01.0°
Distance from Vehicle Left	120cm
Vehicle Width	240cm
Smart	OFF
Sensitivity	High
Audible Warning	Low
Screen Scale	Widescreen
Restore Default Settings	

**Thermal Camera Display Menu**

→ Mounting Height	120cm
Elevation Angle	01.0°
Distance from Vehicle Left	120cm
Vehicle Width	240cm
Smart	OFF
Sensitivity	High
Audible Warning	Low
Thermal/Optical	Fusion
Screen Scale	Widescreen
Restore Default Settings	

**Thermal & Optical Dual-lens Camera Display Menu**

<b>Mounting Height</b>	The height of mounted camera from the horizon, as the <b>H</b> value in the following figure.
<b>Elevation Angle</b>	The angle between the lens optical-axis and the horizon, as the <b>α</b> in the following figure.
<b>Distance from Vehicle Left</b>	The distance between the camera and the left end of the vehicle.
<b>Vehicle Width</b>	The width of the vehicle.
<b>Smart</b>	The passengers in the view will trigger the alarm when Smart is enabled.
<b>Sensitivity</b>	The higher is the sensitivity, the easier the system will trigger the alarm.
<b>Audible Warning</b>	High, Medium, Low, and OFF are selectable. The higher you set the audible warning frequency, the sound of alarm will be higher.



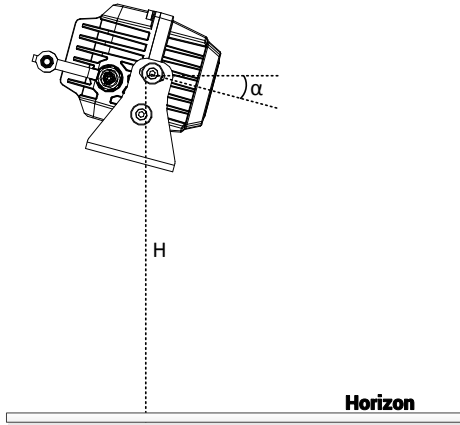



Thermal/Optical	Thermal, Optical, and Fusion are selectable. Select certain mode and the live view shows in such mode.
Screen Scale	Set the scale of the screen display, in <b>Widescreen</b> mode, the screen will be overspread, and in Narrow Screen mode, the live view shows in original scale.
Restore Default Settings	Restore all settings to the default value.



### *Purpose:*

The operation of the driver's system menu is as follows.

### *Step:*

1. Press  and  to select the item.
2. Press  to enter the parameter settings interface. The cursor changes from  $\rightarrow$  to  $\diamond$ .
3. Press  and  to set the value.
4. Press  to confirm the setting.

## 4 System Setup

Before any further use of the system, you should firstly adjust the view, the hardware, and image, etc.

### 4.1 System Correction

**Purpose:**

To ensure the proper working of Smart function, you should correct the system first.

**Step:**

1. Hold the Menu button to enter the menu.
2. Set the **Mounting Height**, **Elevation Angle**, and the **Distance from Vehicle Left**, and **Vehicle Width**.
3. Check whether the lane meets the lane in the display. The right scene is as follow.

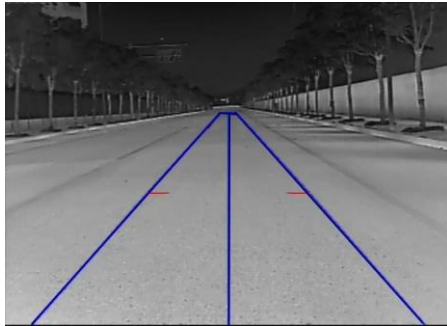

#### Right Scene

- If the lane is above the lane in the display, as in the figure below. Decrease the **Elevation Angle**.



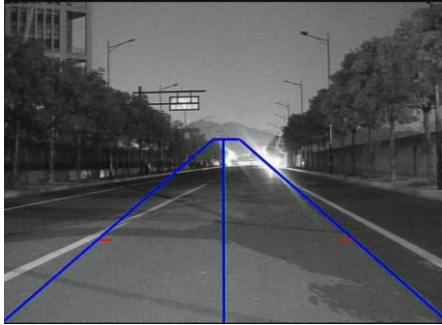

**Lane Above**

- If the lane in the display is too short, as in the figure below. Increase the **Elevation Angle**.

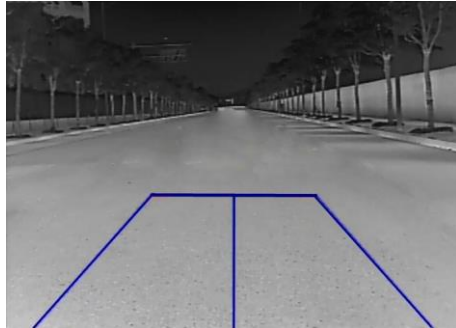

**Short Lane**

## 4.2 De-Ice Heater Configuration

The driver's system supports auto-heating and manual-heating. Set the proper heating mode in concrete cold scene.

### **Auto-Heating:**

- The system detects the lens temperature, when the vehicle is in severely cold weather (temperature < 5 °C/41 °F), the de-ice heater automatically turns on.

- When the lens temperature is heated (temperature > 10°C/32 °F), the de-ice heater automatically turns off.

**Manual-Heating:**

- When there is mist or ice on the lens, enable the heater. The heater icon  shows, and the heater stops when the lens is warm enough.

## 4.3 Palettes Settings

**Purpose:**

For thermal mode and fusion mode, the palettes allow you to select the desired colors.

**Step:**

In the live view interface, press the  key to switch the palettes. White hot, black hot, and green hot are selectable.

1	<b>White Hot</b>	The hot part is light-colored in view.
2	<b>Black Hot</b>	The hot part is black-colored in view.
3	<b>Green Hot</b>	The hot part is green-colored in view.

**Result:**

After setting the palette, the live view will display in the selected palette mode.

## 4.4 Brightness and Contrast Settings

**Before you start:**

The adjustment of image only affects the brightness and contrast of image.

Meanwhile, the adjustment of screen only affects the brightness and contrast of screen.

**Purpose:**

Adjust the brightness and contrast of the display and image.

**Step:**

1. In the live view interface, press the  key to move the cursor. Screen brightness, screen contrast, backlight

brightness, image brightness, image contrast are selectable.

2. Press  or  to increase/decrease the value.

Screen Brightness	Adjust the brightness of the screen. It works for OSD, lane in the display, and image.
Screen Contrast	Adjust the contrast of the screen. It works for OSD, lane in the display, and image.
Image Brightness	Adjust the brightness of the image. It only affects the image.
Image Contrast	Adjust the contrast of the screen. It only affects the image.
Backlight Brightness	Adjust the brightness of the display backlight.

## 5 Smart Detection

When the smart detection is enabled, the system automatically detects the moving objects (including human and animal) in front.

→ Mounting Height	120cm
Elevation Angle	01.0°
Distance from Vehicle Left	120cm
Vehicle Width	240cm
<b>Smart</b>	<b>ON</b>
Sensitivity	High
Audible Warning	Low
Thermal/Optical	Fusion
Screen Scale	Widescreen
Restore Default Settings	

### Menu

When the target-to-vehicle distance is shorter than 100 m, alarm will be triggered.

**Audible Warning Levels:**

High	The beeper beeps every 0.2s.
Medium	The beeper beeps every 0.5s.
Low	The beeper beeps every 1s. Warning level is Low by default.

In the image, the target is framed in different colors:

Red	The target-to-vehicle distance is between 15 m to 40 m.
Green	The target-to-vehicle distance is between 40 m to 100 m.

## 6 Appendix

### 6.1 Content List

Name	Amount
Camera	1
Display (with mount, Velcro)	1
Video Cable (4 m/13.1')	1
Power Cord (1.5 m/4.9')	1
Cigar Light Cable (1.5 m/4.9')	1
Cable Clamp (large)	3
Cable Clamp (small)	4
Wrench	1
Hex Wrench	1
Mount Screw	2
Self-tapping Screw	4

Disassembling Tool	1
Cloth	1

## 6.2 Common Material Emissivity Reference

Material	Temperature (°C/°F)	Emissivity
Water	0 to 100/32 to 212	0.95~0.98
Soil (Dry)	20/68	0.92
Soil (Moist)	20/68	0.95
Wood	17/62.6	0.962
Sand	20/68	0.9
Sandstone	19/66.2	0.909~0.935
PVC (Polyvinyl Chloride)	70/158	0.93
Pitch	20/68	0.967
Paint	70/158	0.92~0.94
Wallpaper	20/68	0.85~0.90
Cloth	20/68	0.98
Concrete	20/68	0.92
Pavement	5/41	0.974
Smooth Porcelain	20/68	0.92
Ceramic	17/62.6	0.94
Plaster	17/62.6	0.86
Brick	35/95	0.94
Ebonite	0 to 100/32 to 212	0.89
Carbon	20 to 400/68 to 752	0.95~0.97
Granite (Rough)	20/68	0.879
CRS (Cold Rolled Steel)	70/158	0.09
Cupric Oxide	50/122	0.88
Copper	20/68	0.07
Copper Oxide	50/122	0.6~0.7



UD09142B

0100001080226